

ALWID-KOMPAKTANLAGE

fully automatic rotary filler with capping machine

The ALWID-KOMPAKTANLAGE is a fully automatic rotary filler, combined with a single head capper as a block system. The machine is suitable for filling and capping low and high viscous, not carbonated liquids into all types of containers.

Further machines can be found on our website www.alwid.de



ill.: ALWID-KOMPAKTANLAGE-12D-1VK



ALWID Sondermaschinenbau GmbH
Wilder Pool 3 · 49413 Dinklage
Tel. +49 4443 96630 · Fax +49 4443 2949
info@alwid.de · www.alwid.de

ALWID-KOMPAKTANLAGE

fully automatic rotary filler with capping machine

Special Characteristics

The ALWID-KOMPAKTANLAGE is suitable for several different filling methods (see below). For the filling of foaming products, under level filling is possible (option). The machine has an electric speed adjustment at the drive, with smooth start and stop movements. Due to gear wheels inside the machine's frame, the filler and inlet and outlet star wheel work synchronously. The single head capping machine is placed right behind the filler. The caps are gently sorted and are fully automatically conveyed to the capping head. Due to the solid and clear construction, the time for a format change is reduced to a minimum (pluggable format parts). Several monitoring devices guarantee a safe operation. The all sides safety casing with doors and safety switches comply to CE standards. A CIP-cleaning is possible (option).

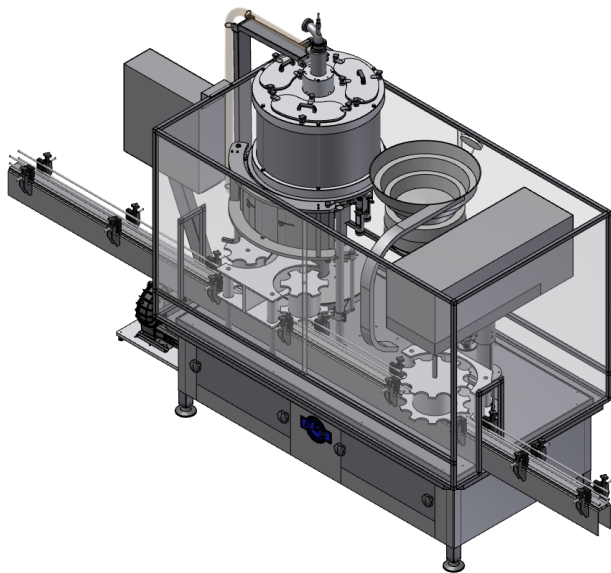

Technical Data

Capacity:	adjustable up to 3.000 bottles/h
Number of filling stations:	6, 8, 10, 12, 16, 18
Number of capping heads:	1
Diameter of filling valve:	dependent on bottle mouth (min. 2 mm)
Working direction:	left – right / right – left
Filling volume:	10-100 ml / 50-500 ml / 100-1000 ml / 200-2000 ml / 500-5000 ml / 1.10 l / or as required
Working height:	850 +/- 50 mm (or as required)
Base made of:	stainless steel
Product touching parts made of:	stainless steel or plastic
Electrical connection:	230/400 V, 50 Hz, 3 phases + N + PE (also available in EX-version) or special
Pneumatic connection:	R 1/2" / 6 bar

Range Of Applicability

The machine is suitable for filling and capping of not carbonated liquids of low- up to high-viscosity into all types of containers (the machine will be suitable for your requirements).

Diameter of bottles :	as required (the machine will be suitable for your requirements)
Height of bottles:	as required (the machine will be suitable for your requirements)
Material of bottles:	containers made of the usual materials
Shape of bottles:	round bottles and molding boxes (shaped bottles)
Liquid filled:	not sparkling liquids of low- up to high-viscosity or paste used in the food-, pharmaceutical or chemical industry
Kind of caps:	several screw-caps, press-in-/press-on-caps, PP, MCA, STELCAP and other roll-on-caps, grip cork, crown cork, twist-off and others

Our Delivery Program:

- filling machines
- capping machines
- feeding- and collecting tables
- conveyor plants
- sorting machines
- special machines
- handling systems